

# Seed Box Tote

## The Most Preferred Bulk Seed Delivery System

Now, gently move your seed with a Speed King Seed Box Tote belt conveyor system. Seed transported by a belt system shows far less signs of breaking or cracking damage caused by the majority of vacuum, plastic cup or brush auger systems.

The tube conveyor provided with the Seed Box Tote offers a belt system for 100% clean-out of seed varieties with no cross contamination unlike an auger system.

Seed carried in the Seed Box Tote is easy to dispense with 180 degrees of horizontal travel with up to a 14' radius for easy and exact placement delivery.

The Seed Box Tote offers a long tube delivery for one stop filling of units up to 40' in width and an adjustable angle from 22 degrees up to 28 degrees.

The Seed Box Tote is easy to transport with the tube pivoted to either the front or back - the unit is only 65" wide.

The Seed Box Tote provides an exceptionally clean seed. The edge skived belt in the tote allows for the best hopper seal available and prevents annoying belt burrs from mixing with the seed.

The Seed Box Tote features a spring-loaded seal for on-demand seed delivery without worrying about closing any gates on the center flow container.

The Seed Box Tote is self-tending and self-feeding - allowing simple push-button delivery.

Conveyor can be locked to either the front or rear for transport.

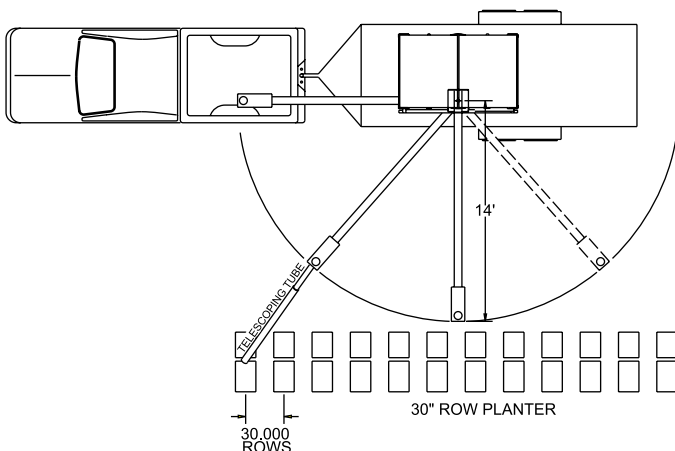

12'-9" ON 54" TRAILER  
10'-3" ON 24" TRAILER

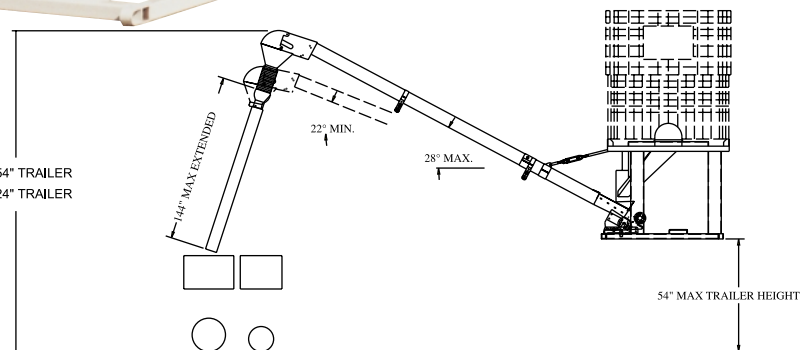

### Standard Features

- 6" tube and an 8" PVC belt
- Telescoping discharge spout
- 3/4 horsepower 12V DC motor
- 304 stainless steel flow channels
- 180 degree pivot range
- 22 degree to 28 degree viable pitch range
- Motor controls conveniently located on discharge spout
- Available in dual seed box models
- Units have fork lift pockets for easy loading of unit
- Optional seed inoculator